

# Sterile Visual Flow Indicator Type "CT" for Hygienic Applications

Patent Pending

Data Sheet 01-0085 03/20

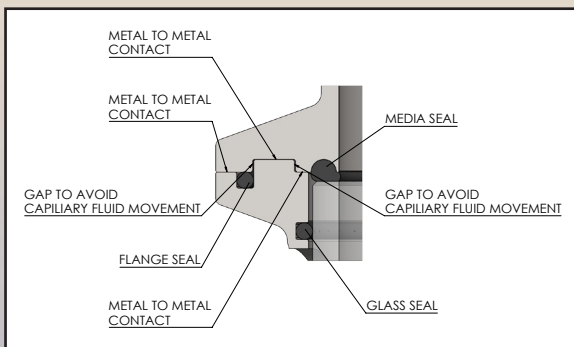
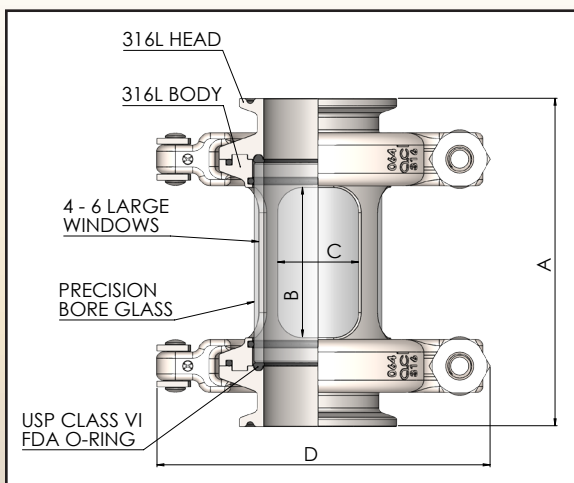

**D**esigned to be mounted in-line for high purity hygienic applications, these clamp type "CT" sterile-design visual flow indicators provide operators with a clear view of flow for virtually any process pipeline fluid or powder. They feature an internal-flush style based on a unique O-ring seal design that minimizes traps where bacteria can buildup. Polished stainless steel sanitary clamp connections are standard with orbital weld, Swagelok TS, flange or union connections as special order items.

#### Other premium standard features

- Mechanical stop for controlled gasket compression
- Eliminates thread galling and loosening of unit
- Prevents torsional distortion of o-rings typical with threaded designs
- No tools for easy assembly and disassembly
- Up to 34% increased viewing
- Precision bore borosilicate glass
- Product contact surface of SF4 (15 Ra Max, EP)
- Armored housing protects glass from objects and pipe stress.
- Units can be used during SIP/CIP and sterilizing/autoclaving.

#### Other Certifications

- FDA & USP Class VI certified o-rings
- EN10204 3.1 certification for steel work
- European Pressure Equipment Directive 97/23/EC
- Borosilicate 3.3 viewing cylinder (10:1 FOS)

Units are available from stock in tube OD sizes from 1/2 to 4 inches with standard lengths shown below. Depending on OD, units are rated to 150 PSIG. Custom designed lengths, connection sizes and types are also available.

Standard material of construction is 316L Stainless Steel with full material traceability ASME (BPE Standards). For corrosive service, Hastelloy® and AL6XN® are also available. All gaskets are USP Class VI and FDA certified and are fully traceable. EPDM is the standard O-ring material with Silicone, Viton®, and FEP jacketed Silicone as options.

For additional information and applications assistance contact:

**L.J. Star Incorporated**

P.O. Box 1116, Twinsburg, OH 44087

Phone: (330) 405-3040 • Fax: (330) 405-3070

Web Page: [www.ljstar.com](http://www.ljstar.com) • e-mail: [info@ljstar.com](mailto:info@ljstar.com)

**L.J. STAR**  
INCORPORATED

Tube OD	Base P/N	Length A	Window B x C	Width D	No. of Windows	Integral Clamp Size	Pressure PSI	Weight lbs.
1/2"	SVFCT-A05AA1B	76	24 x 8	85	4	DN10/15/20	290	1.3
3/4"	SVFCT-A07AA1B	87	29 x 13	102	4	1", 1-1/2"	253	2.0
1"	SVFCT-A10AA1B	90	34 x 16	102	4	1", 1-1/2"	123	2.2
1-1/2"	SVFCT-A15AA1B	105	48 x 26	123	4	2"	116	2.6
2"	SVFCT-A20AA1B	120	55 x 36	140	4	2-1/2"	102	3.4
2-1/2"	SVFCT-A25AA1B	151	72 x 33	150	6	3"	94	4.2
3"	SVFCT-A30AA1B	175	108 x 36	165	6	3-1/2"	94	5.5
4"	SVFCT-A40AA1B	200	135 x 48	191	6	4-1/2"	58	7.7

\* All dimensions in mm unless otherwise stated